



IMPORTANT FOR FUTURE REFERENCE	
Please complete this information and retain this manual for the life of the equipment:	
Model #:	_____
Serial #:	_____
Date Purchased:	_____

Installation & Operation Manual

Direct Steam Tilting Kettles

KDLT-20, KDLT-30, KDLT-40, KDLT-60, KDLT-80 & KDLT-100

KDPT-20, KDPT-30, KDPT-40, KDPT-60 & KDPT-80



Model KDLT



Model KDPT

WARNING

Improper installation, adjustment, alteration, service or maintenance can cause property damage, injury or death. Read the installation, operating and maintenance instructions thoroughly before installing or servicing this equipment.

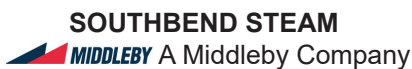

1100 Old Honeycutt Road Fuquay-Varina, North Carolina 27526 USA
www.southbendnc.com



SAFETY PRECAUTIONS

Before installing and operating this equipment, be sure everyone involved in its operation is fully trained and aware of precautions. Accidents and problems can be caused by failure to follow fundamental rules and precautions.

The following symbols, found throughout this manual, alert you to potentially dangerous conditions to the operator, service personnel, or to the equipment.



This symbol warns of immediate hazards that will result in severe injury or death.



This symbol refers to a potential hazard or unsafe practice that could result in injury or death.



This symbol refers to a potential hazard or unsafe practice that could result in injury, product damage, or property damage.



This symbol refers to information that needs special attention or must be fully understood, even though not dangerous.

IMPORTANT NOTES FOR INSTALLATION AND OPERATION

WARNING

This is the safety alert symbol. It is used to alert you to potential personal injury hazards. Obey all safety messages that follow this symbol to avoid possible injury or death.

WARNING

FOR YOUR SAFETY:

Do not store or use gasoline or other flammable vapors or liquids in the vicinity of this or any other appliance.

WARNING

Improper installation, operation, adjustment, alteration, service or maintenance can cause property damage, injury or death. Read the installation, operating and maintenance instructions thoroughly before installing, operating or servicing this equipment.

NOTICE

This product is intended for commercial use only. NOT FOR HOUSEHOLD USE.

NOTICE

Contact the factory, the factory representative or local service company to perform maintenance and repairs.

NOTICE

This manual should be retained for future reference.

RETAIN THIS MANUAL FOR FUTURE REFERENCE.

Table of Contents

Important Notes For Installation and Operation	2
Service Connections	4
Installation	6
Introduction	7
Description	7
Basic Functioning	7
Capacities	7
Functioning Mode	7
Operation	8
Cleaning.....	9
Maintenance	10
Troubleshooting	11

SERVICE CONNECTIONS

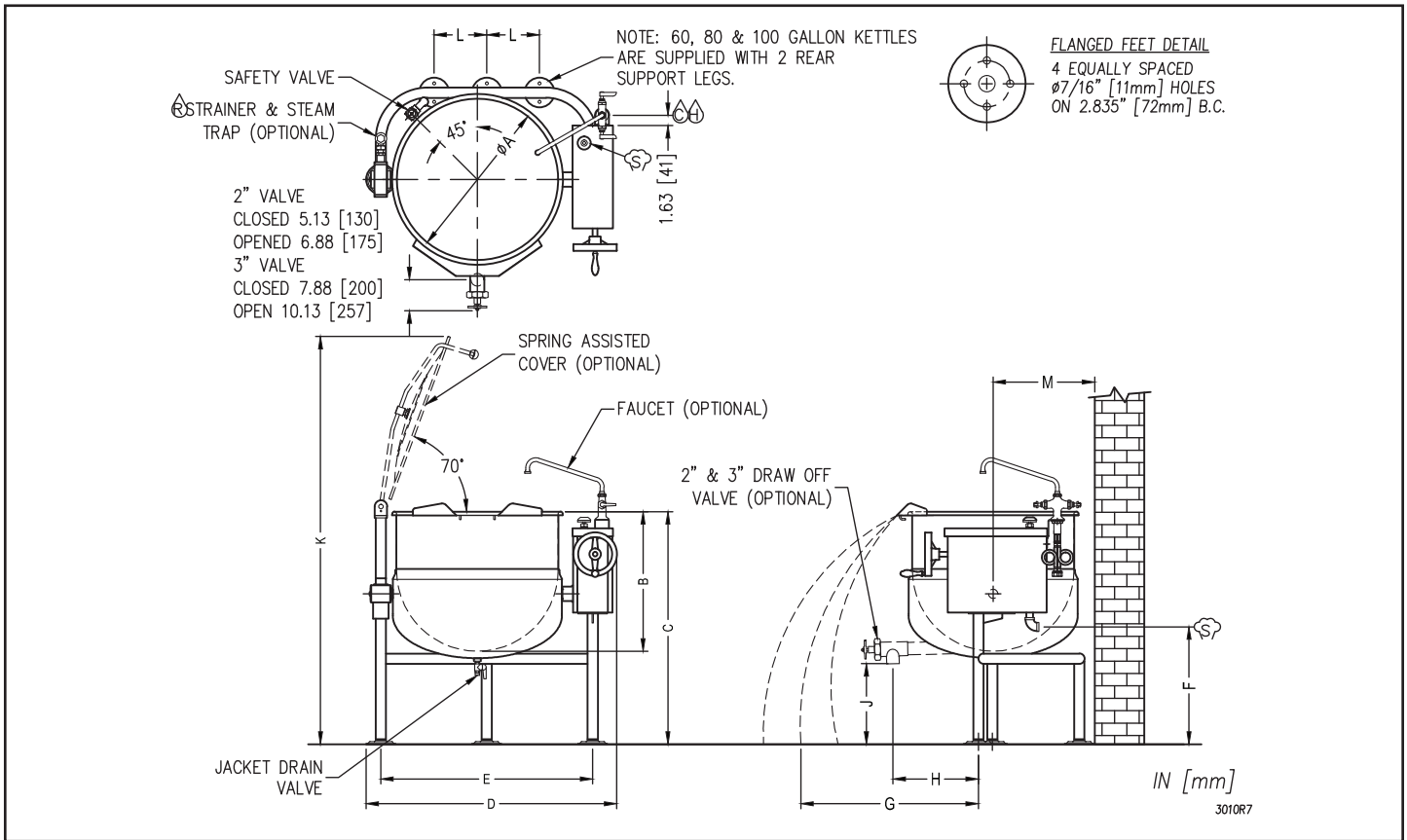

SERVICE CONNECTIONS

- ☁ – STEAM SUPPLY: 3/4" IPS (19 mm) 5-30 PSI (34-206 kPa).
Optional 5-45 PSI (34-310 kPa).
- ☁ – COLD WATER: 3/8" O.D. tubing to faucet. (OPTIONAL)
- ☁ – CONDENSATE RETURN: 1/2" IPS (13 mm)
- ☁ – HOT WATER: 3/8" O.D. tubing to faucet. (OPTIONAL)

(Pressure reducing valve required if pressure is over 50 PSI)

DIMENSIONS

MODEL	CAPACITY	UNITS	A	B	C	D	E	F	G	H(2")	H(3")	J(2")	J(3")	K	L	M
KDLT-20	20 gallons (76 liters)	in (mm)	21" (533)	18" (460)	37" (940)	34.75" (885)	28.5" (724)	20.38" (518)	25.63" (651)	12" (305)	13.25" (337)	17" (432)	16.13" (410)	60.63" (1540)	N/A	15.38" (391)
KDLT-30	30 gallons (114 liters)	in (mm)	24" (610)	20" (510)	37" (940)	37.75" (960)	31.5" (800)	19.88" (505)	27.13" (689)	13.13" (333)	14.25" (362)	15" (381)	14.5" (368)	63.25" (1607)	N/A	15.38" (391)
KDLT-40	40 gallons (152 liters)	in (mm)	26" (660)	22.5" (570)	37" (940)	39.88" (1013)	33.5" (850)	18.38" (467)	28.63" (727)	13.75" (349)	15.25" (387)	12.5" (318)	12" (305)	65.25" (1657)	N/A	16.38" (416)
KDLT-60	60 gallons (227 liters)	in (mm)	29.5" (750)	26" (660)	40.5" (1029)	43.25" (1100)	37" (940)	19.25" (489)	30.13" (765)	15.5" (394)	16.88" (429)	14" (356)	14" (356)	74" (1879)	9.5" (241)	18.38" (467)
KDLT-80	80 gallons (303 liters)	in (mm)	33" (840)	28" (710)	42.5" (1080)	46.75" (1085)	40.5" (1030)	20.25" (514)	32.63" (828)	17.13" (435)	16.88" (429)	12.5" (318)	12" (305)	77" (1956)	11" (279)	19.88" (505)
KDLT-100	100 gallons (379 liters)	in (mm)	35.5" (902)	30" (762)	42.5" (1080)	49.25" (1251)	43" (1092)	19.13" (486)	39.25" (997)	18" (457)	20.25" (514)	10.5" (267)	10" (254)	79.25" (2013)	12.5" (318)	21.5" (546)

SPECIFICATIONS

MODEL	SHIPPING WEIGHT	MINIMUM CLEARANCE		MODEL	SHIPPING WEIGHT	MINIMUM CLEARANCE	
KDLT-20	215 lbs. [98 kg]	SIDES	0 [0]	KDLT-60	385 lbs. [177 kg]	SIDES	0 [0]
KDLT-30	285 lbs. [129 kg]			KDLT-80	424 lbs. [192 kg]		
KDLT-40	332 lbs. [151 kg]	BACK	0 [0]	KDLT-100	480 lbs. [218 kg]	BACK	0 [0]

As continued product improvement is a policy of Southbend Steam, specifications are subject to change without notice.

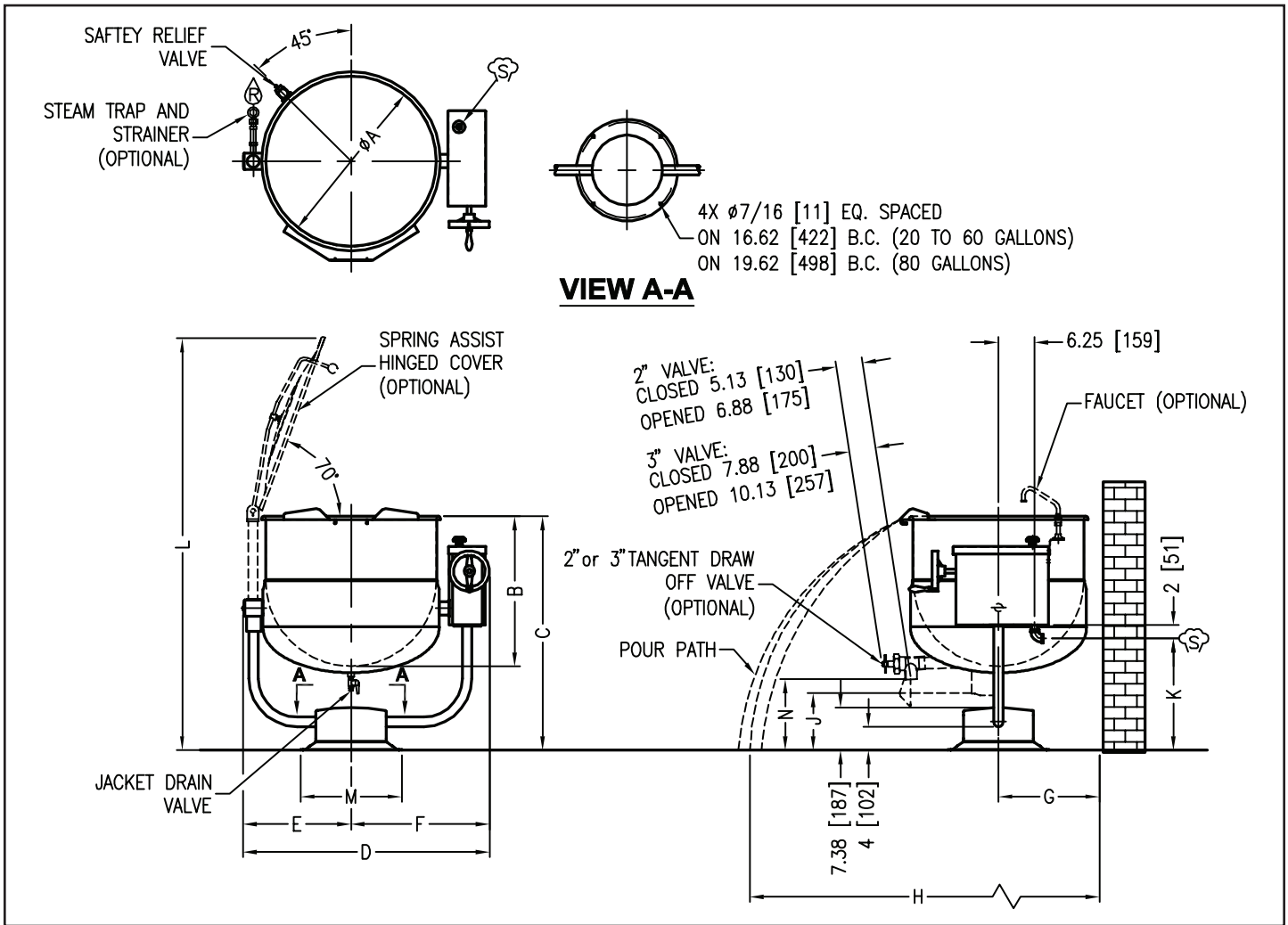

SERVICE CONNECTIONS

☁ – STEAM SUPPLY: 3/4" IPS (19 mm) 5-30 PSI (34-207 kPa). Optional 5-45 PSI (34-310 kPa)*

Ⓡ – CONDENSATE RETURN: 1/2" IPS (13 mm)

* Pressure reducing valve is required if incoming pressure exceeds 50 PSI (345 kPa).

DIMENSIONS

MODEL	CAPACITY	UNITS	A	B	C	D	E	F	G	H	J	K	L	M	N(2")	N(3")
KDPT-20	20 gallons (76 liters)	in (mm)	21" (535)	18" (460)	37" (940)	34.75" (883)	14.75" (375)	20" (508)	13.5" (343)	41" (1041)	15.25" (387)	20.5" (521)	59.5" (1512)	17.5" (445)	16.75" (425)	16.25" (413)
KDPT-30	30 gallons (114 liters)	in (mm)	24" (610)	20" (510)	37" (940)	37.75" (959)	16.25" (413)	21.5" (546)	14" (356)	43" (1092)	13.25" (337)	20" (508)	62.5" (1588)	17.5" (445)	14.75" (375)	14.25" (362)
KDPT-40	40 gallons (152 liters)	in (mm)	26" (660)	22.5" (570)	37" (940)	39.75" (1010)	17.25" (438)	22.5" (572)	15.5" (394)	45" (1143)	10.75" (273)	18.5" (470)	64" (1626)	17.5" (445)	12.25" (311)	11.75" (298)
KDPT-60	60 gallons (227 liters)	in (mm)	29.5" (750)	26" (660)	40.5" (1029)	43" (1092)	18.88" (479)	24.13" (613)	17.5" (445)	48" (1219)	10.25" (260)	19.25" (489)	74" (1879)	17.5" (445)	14.25" (362)	13.75" (349)
KDPT-80	80 gallons (303 liters)	in (mm)	33" (840)	28" (710)	42.5" (1080)	46.5" (1181)	20.63" (524)	25.88" (657)	19" (483)	52" (1321)	9.75" (248)	20.5" (521)	76" (1930)	20.5" (521)	12.25" (311)	11.75" (298)

As continued product improvement is a policy of Southbend Steam, specifications are subject to change without notice.

INSTALLATION

UNPACKING

IMMEDIATELY INSPECT FOR SHIPPING DAMAGE

Immediately after unpacking the steamer, check for possible shipping damage. If the steamer is found to be damaged, save the packaging material and contact the carrier within 15 days of delivery.

Prior to installation, verify that the type of gas supply (natural or propane) and electrical service agree with the specifications on the rating plate located on the left side panel as you face the front of the braising pan. If the supply and equipment requirements do not agree, contact your dealer immediately.

INSTALLATION INSTRUCTIONS

1. Select a location to provide drainage for kettle pour path when tilted and for draw-off valve if so equipped.
2. Mark hole locations through flanged adjustable feet on KDLT models and through pedestal base on KDPT models. Remove kettle.
3. On hole locations marked, drill holes and insert expansion shields to accommodate 5/16" size lag bolts.
4. Reposition kettle. On KDLT models level kettle by making necessary adjustment on flanged foot.
5. Bolt down kettle and seal with Silastic or other equivalent sealing compound. Sealant must be applied not only to bolt heads but also around flanges or pedestal base making contact with floor surface to fulfil NSF requirements.
6. Connect steam line (3/4" pipe size) to the kettle, making sure there is a steam control valve strainer fairly convenient to the kettle.
7. Connect kettle condensate return line to a drain or to a boiler return line. Each kettle return line must have a suitable steam trap. Boiler return lines must have a check valve.
8. Safety relief valve on kettle must not be plugged as it is set to relieve excess pressure in the kettle.
9. If incoming steam pressure is greater than kettle maximum operation pressure then a pressure reducing valve must be installed in the line.
10. If large amounts of water accumulate in the steam line it will be necessary to install one or more ball float traps in the line to eliminate the water.
11. A steam line pressure gauge is also recommended to determine the actual amount of steam being supplied to the kettle.
12. Check for proper operation.

INTRODUCTION

DESCRIPTION

All Southbend Steam direct connected steam jacketed kettles pertaining to this manual are direct steam operated pressure vessels of a double-wall stainless steel construction forming a steam chamber (jacket) enveloping the lower two thirds of the kettle bowl surface. All kettles are tilting, floor mounted in fixed positions either on legs with adjustable flanged feet (KDLT Models) or pedestals (KDPT Models). All kettles are equipped with a drain cock, safety relief valve and a steam control valve. Options on kettles include hinged spring assisted stainless steel lid covering the kettle bowl opening and a sanitary stainless steel tangent draw-off valve as an alternate method for the removal of the food product from the kettle bowl.

BASIC FUNCTIONING

CAPACITIES

All models are suffixed with either - 20, - 30, - 40, - 60, - 80 or - 100 to indicate the capacity of that kettle in U.S. gallons. Thus a KDLT-40 is a two thirds jacketed direct steam kettle mounted on legs with a capacity of 40 gallons (U.S.). If the letter F is added to the suffix, this indicates that the kettle is full jacketed direct steam kettle with a capacity of 40 gallons (U.S.).

FUNCTIONING MODE

Southbend Steam direct connected steam jacketed kettles consist of a stainless steel bowl and a stainless steel jacket which envelopes two thirds of the lower surface of the bowl thus forming a sealed pressure vessel (chamber) into which steam is introduced by means of a manual control valve.

The kettle bowl is the container for the food product which ideally should be of a liquid or semi-liquid consistency to achieve complete contact with the bowl surface and thus fully absorb the heat transmitted through the surface.

The temperature required for the cooking process to function adequately must be greater than the boiling point of the liquid food product. Further, the greater the steam pressure used, the higher the temperature and consequently the quicker the cooking process. For example, steam pressurized at 30 p.s.i. attains a temperature of 274 degrees Fahrenheit (135 degrees Celsius).

OPERATION

 **WARNING**

The kettle and its parts are hot. Use care when operating, cleaning and servicing the kettle.

OPERATING INSTRUCTIONS

1. If kettle has draw-off valve, close it.
2. Fill kettle with product to desired level.
3. Slowly turn the steam control valve ON to full open position (counterclockwise).
4. The water or food should boil 2 to 3 gallons per minute. If it does not then incoming pressure and piping should be checked to determine that it is adequate to operate the kettle efficiently.
5. Regulate steam control valve depending on type of food being prepared.
6. When food is cooked, turn off steam, remove food and clean kettle immediately to prevent residue from drying on kettle bowl surface.

CLEANING

 **WARNING**

Disconnect the power supply to the appliance before cleaning or servicing.

 **WARNING**

Never spray water into electric controls or components!

 **WARNING**

The equipment and its parts are hot. Use care when operating, cleaning and servicing.

Your kettle should be cleaned immediately after each use.

1. Ensure that steam supply is OFF.
2. Pre-rinse inside of kettle thoroughly and drain to remove any food particles.
3. Using a nylon brush, clean kettle with a mild detergent and warm water rinse. Never use steel wool or scouring powder as it will scratch stainless steel.
4. Tilt kettle fully or open the tangent draw-off valve if one is provided to allow soap and water solution to drain. Rinse with clean water.
5. On kettles equipped with a draw-off valve, turn the large hex nut counterclockwise by hand until it is completely disengaged from the thread. Grasp knob to valve and slowly pull out valve stem and disc. Do not allow disc to come in contact with hard surfaces since damage to disc may occur and result in valve leakage. Wash the valve stem, disc and handle. Insert nylon brush with detergent into interior of valve body and tangent draw-off tube and brush vigorously. Replace valve stem assembly and engage hex nut fully by hand. Flush kettle with clean warm water. Leave valve open when kettle is not in use.

 **CAUTION**

Do not use cleaning agents that are corrosive.

Use of cleaning agents that contain chloride, acids or salts are corrosive and may cause pitting and corrosion when used over a period of time; this will reduce the life of the appliance.

Should pitting or corrosion occur, this is not covered by warranty.

Follow the recommended cleaning instructions. Use a mild detergent, warm water and rinse thoroughly.

MAINTENANCE

PREVENTIVE MAINTENANCE

No preventive maintenance is required other than adhering to the Cleaning Procedure instructions.

SAFETY VALVE MAINTENANCE AND TESTING

CAUTION

Under normal operating conditions a “try lever test” should be performed every two months. Under severe service conditions, or if corrosion and/or deposits are noticed within the valve body, testing must be performed more often. A “try lever test” should also be performed at the end of any non-service period.

CAUTION

Hot, high pressure fluid may be discharged from body drain and vent during “try lever” test. Care must be taken to avoid any bodily contact.

CAUTION

High sound levels may be experienced during “try lever” test. Wear proper safety equipment and exercise extreme care! Test at, or near, half of the operating pressure by holding the test lever fully open for at least two seconds to flush the valve seat free of sediment and debris. Then release lever and permit the valve to snap shut.

If lift lever does not activate, or there is no evidence of discharge, turn off equipment immediately and contact a licensed contractor or qualified service personnel.

TROUBLESHOOTING

DRAW-OFF VALVE LEAKS

If leak occurs through the valve stem, replace the “O” ring. If the leak can be attributed to faulty sealing occurring between the stem disc and valve seat, then this may be due to dried on food residue. Clean the dried on food residue with an extremely fine emery cloth. If the rubber vulcanized stem piece has been damaged it must be replaced.

NOTICE

Draw-off valve has a vulcanized rubber coated stem for better sealing. Do not over tighten. This may cause the rubber to pull away from stem and permanently damage it. This is not covered under warranty.

EXTREMELY SLOW COOKING TIME

If the cooking time is abnormally slow then the difficulty may be due to insufficient steam pressure and/or volume.

First determine that pressure on incoming steam line at kettle is within 5 p.s.i. of rated kettle pressure.

NOTICE

Pressures approaching the rated kettle pressure are liable to set off the safety relief valve.

If required pressure is available to kettle, then possibly volume of steam is not sufficient. Minimum 3/4” pipe size is required to the kettle but if the steam generating source is at a great distance from the kettle, larger pipe will be required.

Finally, the core of the steam supply pipe may have debris or scalants that impede steam flow and will require disassembly and inspection.

VENTING INSTRUCTIONS

It is recommended that the “optional” steam trap assembly be installed. This should be plumbed to the exit end of the kettle. The thermostatic trap is a mechanical device that closes on high temperature and opens when the temperature drops, allowing the water which formed from condensate to exhaust but retain the steam under pressure.

The temperatures required for the cooking process to function adequately must be greater than the boiling point of the liquid food product, that is, water. The greater the steam pressure used, the higher the temperature and the quicker the cooking process. For example, steam pressurized at 30 p.s.i. reaches a temperature of 274 degrees Fahrenheit (135 degrees Celsius). Since air is an unsuitable media through which heat may be transferred, the air should be exhausted from the jacket by opening the pressure relief valve until the air has been completely replaced by pressurized steam.

In the initial stages of the cooking process when the steam comes in contact with the cold kettle bowl surface, it condenses and forms a large amount of water. The condensate water must be removed from the kettle jacket in order for the kettle to function adequately. The ball valve located at the base of the kettle jacket may be opened to remove the water. It may be necessary to repeat this procedure several times depending on the number of batches being cooked as each batch will create condensate. If the kettle appears to be slow in heating, this would indicate that there is water in the jacket. Open ball valve and drain. Close valve and commence operation of kettle.

KDLT-20, KDLT-30, KDLT-40, KDLT-60,
KDLT-80 & KDLT-100
KDPT-20, KDPT-30, KDPT-40, KDPT-60 & KDPT-80
**DIRECT STEAM
TILTING KETTLES**



A product with the Southbend Steam name incorporates the best in durability and low maintenance. We all recognize, however, that replacement parts and occasional professional service may be necessary to extend the useful life of this appliance. When service is needed, contact a Southbend Steam Authorized Service Agency, or your dealer. To avoid confusion, always refer to the model number, serial number, and type of your appliance.



SOUTHBEND STEAM
 **MIDDLEBY** A Middleby Company
1100 Old Honeycutt Road Fuquay-Varina, North Carolina 27526 USA
www.southbendnc.com